

LEGIBILITY NOTICE

A major purpose of the Technical Information Center is to provide the broadest dissemination possible of information contained in DOE's Research and Development Reports to business, industry, the academic community, and federal, state and local governments.

Although a small portion of this report is not reproducible, it is being made available to expedite the availability of information on the research discussed herein.

CONF-900563--4
RECEIVED BY OST
MAY 03 1990

Los Alamos National Laboratory is operated by the University of California for the United States Department of Energy under contract W-7405-ENG-36

LA-UR--90-1372

DE90 010609

TITLE: APPLICATION OF GAMMA-RAY SPECTROMETRY
IN THE QUANTITATIVE NONDESTRUCTIVE ASSAY
OF SPECIAL NUCLEAR MATERIALS

AUTHOR(S): Thomas E. Sampson and Jack L. Parker

SUBMITTED TO: Seventh Symposium on Radiation Measurements
and Applications
Ann Arbor, Michigan
May 21-24, 1990

DISCLAIMER

This report was prepared as an account of work sponsored by an agency of the United States Government. Neither the United States Government nor any agency thereof, nor any of their employees, makes any warranty, express or implied, or assumes any legal liability or responsibility for the accuracy, completeness, or usefulness of any information, apparatus, product or process disclosed, or represents that its use would not infringe privately owned rights. Reference herein to any specific commercial product, process, or service by trade name, trademark, manufacturer, or otherwise does not necessarily constitute or imply its endorsement, recommendation, or favoring by the United States Government or any agency thereof. The views and opinions of authors expressed herein do not necessarily state or reflect those of the United States Government or any agency thereof.

By acceptance of this article the publisher recognizes that the U S Government retains a nonexclusive, royalty-free license to publish or reproduce the published form of this contribution or to allow others to do so, for U S Government purposes

The Los Alamos National Laboratory requests that the publisher identify this article as work performed under the auspices of the U S Department of Energy

MASTER

Los Alamos Los Alamos National Laboratory
Los Alamos, New Mexico 87545

MASTER DISTRIBUTION OF THIS DOCUMENT IS UNLIMITED

APPLICATIONS OF GAMMA-RAY SPECTROMETRY IN THE QUANTITATIVE NONDESTRUCTIVE ASSAY OF SPECIAL NUCLEAR MATERIALS

Thomas E. Sampson and Jack L. Parker
Los Alamos National Laboratory, Los Alamos, NM 87545, USA

ABSTRACT

Nearly all applications of gamma-ray spectrometry in the quantitative assay of special nuclear materials can be grouped into five general categories. They are as follows: (1) Quantitative passive assay, of which transmission-corrected passive assay methods for measuring isotopic masses/concentrations are an important subset; (2) Enrichment measurements on "infinitely thick" samples for absolute determination of isotopic fractions/concentrations; (3) Measurements of isotopic ratios using relative detection efficiency principles resulting in absolute isotopic distributions without recourse to standards; (4) Absorption-edge densitometry measurements of elemental concentrations; and (5) X-ray fluorescence measurements of elemental concentrations.

Careful and correct practice of these techniques can yield measurement accuracies in the range of 0.1% to 1.0% in favorable situations with measurement times generally in the range of 15 minutes to 1 hour.

We present examples of these general categories with emphasis on those measurements and techniques exhibiting the best accuracy, as well as those which are not routinely practiced in many other applications of gamma-ray spectrometry.

I. INTRODUCTION

Quantitative nondestructive assay of special nuclear materials (SNM) plays an important role in the accountability of these valuable and strategic materials. Over the past 20 years several generic techniques, with a multitude of variation in application, have been developed to perform these measurements using gamma-ray spectrometry. Such measurements can, in many instances, supplant more traditional analytical chemistry techniques and are often chosen because of their rapidity and lower cost. We will describe several methods that are routinely used for the quantitative assay of SNM (usually the isotopes of uranium, plutonium, and americium) with emphasis on measurements that exhibit the best accuracy. We will also emphasize measurement principles that, while widely known, are often not routinely practiced in many other applications of gamma-ray spectrometry. A more complete description of these techniques may be found in the book "Passive Nondestructive Assay" to be published by the Nuclear Regulatory Commission.

II. DATA ACQUISITION

Measurement systems for the techniques discussed below have been designed, constructed, tested, and implemented in routine facility use by the Safeguards Assay Group of the Los Alamos National Laboratory as well as by other developers. Users will find two features that are common to many of the Los Alamos systems: the use of external isotopic sources for making rate-loss corrections (for pileup and deadtime losses), and the use of digital gain and zero stabilization for increased spectral acquisition stability.

A. Rate-loss Correction Sources

Isotopic sources are used to make accurate corrections for pileup and deadtime counting losses over a wide dynamic range of detector count rates. These sources are usually small (μCi), commercially available, disc sources rigidly fixed to the endcap of the Ge (usually) detector. The assumption in their use is that all photopeaks in the spectrum suffer the same fractional losses from deadtime and pileup. This is not strictly true because the variation of peak-width with energy can make pileup losses slightly greater for narrow peaks than broader peaks. However, careful application of the technique (best applied with simple region-of-interest (ROI) peak-area summation methods) shows that it can be accurate to better than 0.5% over a count-rate range of a few kHz to over 100 kHz. With the use of a rate-loss correction source, all analysis is done with the ratio of the assay-peak area/rate-loss source peak area. This ratio is independent of the loss fraction so actual rate-loss correction factors need not be explicitly computed; they are automatically incorporated in the analysis.

Commonly used rate-loss correction sources are: 59.5 keV ^{241}Am , 88 keV ^{109}Cd , 122 keV ^{57}Co , and 356 keV ^{133}Ba with desirable properties being an energy near to, but below, that of the assay peak and a long, well-known half-life. Source strength is chosen so that the count rate in the rate-loss peak is high enough to not significantly add to the statistical error of the assay peak. Usually 1000 counts/s or less in the rate-loss photopeak is sufficient.

B. Digital Gain/Zero Stabilization

These commercially available modules are found in most assay systems used for SNM measurements. They are especially valuable with analysis methods using ROI peak-area methods because of the importance of knowing exact peak positions and the desirability of not using software to find peak positions. We also do not find any significant loss of resolution in their use. The computer controllable feature of most

stabilizers is invaluable in systems that analyze data from separate acquisitions with different isotopes.

III. METHODS FOR ISOTOPIC MASSES/CONCENTRATIONS

Because gamma-ray emission is isotope specific, most methods that use the passive emissions from naturally radioactive materials are sensitive to the isotope mass or concentration in the sample.

A. Transmission-corrected Passive Assay

The principles of this measurement method form the basis for many of the gamma-ray spectrometry techniques currently in use for measuring SNM. Features of this general application are also found in the XRF measurements mentioned later in this paper. This method measures the transmission of gamma rays through the sample from a source external to the sample. The measured transmission of the external-source gamma rays is used to calculate the linear attenuation coefficient (μ) of the bulk sample at the energy of the assay peak. Knowledge of the μ of the sample enables one to calculate the fraction of assay-peak gamma rays produced within the sample that escape the sample unattenuated. This fraction is the correction factor for attenuation within the sample. This correction factor, in conjunction with the rate-loss corrections discussed above, allows this technique to be accurate over a wide range of sample sizes, matrix compositions and densities, and SNM concentrations.

There are some restrictions to the technique [1]. The sample must be sufficiently homogeneous that the sample material can be characterized for small volume elements by a single, linear attenuation coefficient because the determination of the sample μ from the transmission measurement is the key to obtaining an accurate and representative correction factor. It is also required that the individual gamma-ray emitting particles be small enough

that self-attenuation within the particles is negligible. This requirement arises because the transmission measurement accounts for attenuation of the gamma rays after escape from the parent particle, but does not account for attenuation within the parent particle. The sample geometry should also be simple, making it amenable to correction-factor calculations.

1. Transmission Sources. Transmission sources should have gamma rays bracketing or near to the assay peak so that the transmission at the assay-peak energy can be easily interpolated or extrapolated from the measured transmission. Selenium-75 is a useful source because its gamma rays at 121, 136, 279, and 401 keV allow interpolation and extrapolation to all of the major assay peaks of ^{235}U (185 keV) and ^{239}Pu (129 and 414 keV). Its 120-day half-life is adequate with source replacement required approximately twice a year. Ytterbium-169 (177 and 198 keV) is also used in the assay of ^{235}U (185 keV). Its 32-day half-life is shorter than desired, necessitating fairly frequent source replacement.

2. Transmission Correction Factors. The transmission correction factors are usually calculated numerically for each measurement with the measured sample transmission being the independent variable. The geometry of the sample and the sample-collimator-detector configuration are the key parameters in determining the type of calculation to be done. For so-called far-field measurements in which the sample-detector distance is large compared to sample dimensions, correction factors can often be adequately calculated from analytical expressions (exact or approximate) of which the familiar slab correction factor, $-\ln T/(1-T)$, is an example. More compact measurement geometries usually require numerical calculations that include the exact geometry. These can be carried out in one, two, or three dimensions, depending upon the problem. One- and two-dimension correction-factor calculations can be done on-line with current computing capability. Three-dimensional calculations require off-line calculations to parameterize the

correction factor as a function of the transmission T . The parameterized correction factor is then used on-line. Reference [1] describes the use and calculation of attenuation correction factors in great detail.

3. Calibration. The use of transmission (attenuation) corrections and rate-loss corrections greatly simplifies the calibration of the measurement system. With accurate corrections the total-corrected count rate becomes directly proportional to the SNM mass in the sample as defined in Eqs. 1 and 2.

$$M = TCR/K, \quad (1)$$

where M = Mass, K = Calibration Constant, and TCR = Total Corrected Rate.

$$TCR = RR \cdot CF(RL) \cdot CF(ATT), \quad (2)$$

where RR = Raw (uncorrected) Rate observed in photopeak, $CF(RL)$ = Correction Factor for Rate Loss, and $CF(ATT)$ = Correction Factor for Attenuation.

No longer is there a need to have standards that are "representative" of, or matched to, the unknowns. The correction factors take care of the differences, even to the extent of having different container/sample sizes and geometries between calibration standards and unknowns. This is the principal advantage of this technique; one that has not been used in the safeguards and other fields as much as, perhaps, it should. These forms also apply, with differences only in the specific form of $CF(ATT)$, to the x-ray fluorescence measurements described later.

Calibration standards should be well-characterized, uniform, homogeneous materials that have accurately known SNM values. Typically, the known SNM values are obtained from chemical analysis of the material in the standards. So, while the

measurement technique can replace routine chemical analysis, we still must obtain values for our calibration standards from accurate chemical analysis.

Correct application of correction factors makes the calibration curve linear with a zero intercept. In principle, a single standard can suffice for system calibration. In practice, it is desirable to use more standards, both to check on the self-consistency of the standards, and to quantify any possible small nonlinearities in the calibration curve [1,2,3]. Careful delineation of calibration curve nonlinearities may help to define small mass/concentration dependent biases [2,3,4].

The single calibration constant for a transmission-corrected passive assay is usually calculated in the units of (corrected count rate)/(gram SNM) or (corrected count rate)/(gram SNM/liter).

B. Applications/Performance

1. Solutions. Solutions are an ideal example for the application of this technique because they are uniform and homogeneous, do not (ideally) have finite-sized particles, and can be confined in an accurately known geometry. An example of the application of the transmission-corrected, passive-assay technique to the measurement of ^{235}U in solution is described in [2,3]. These references describe a system that measures solutions with uranium concentrations ranging from 0.1 mg/l to over 400 g/l, a dynamic range approaching 10^7 . A measurement station from this system is shown in Fig. 1, which represents a typical transmission-corrected, passive-assay measurement geometry.

A set of calibration data from two sets of solution standards at the high end of this system's measurement range is shown in Fig. 2.

It is seen that not all of the standards are consistent, an excellent example of the desirability of using more than a single calibration standard. With such a system it is easy to observe inconsistencies among a series of calibration standards. In this case the inconsistencies were attributed to incorrect characterization of the standards by chemical

analysis. We also observe that 10 of the 14 standards show a consistency that demonstrates assay system calibration errors of less than 0.2% for uranium concentrations from 5 to 500 g/l. This example illustrates that the application of this gamma-ray spectrometry technique, under good conditions, can give results equal to those from careful chemical analysis.

This system used a two-dimensional, on-line calculation of the attenuation correction factor as well as an ^{241}Am rate-loss source with the assay peak being the 185 keV peak of ^{235}U . Over the above concentration range the transmission correction factor changes by about a factor of 1.5 while the rate loss correction factor varies by nearly a factor of 2 giving a total correction factor change on the order of 2.5-3.

2. Uniform, Homogeneous Solids. In principle, these materials should produce assays as good as those from solutions. However, solids (powders and powder mixtures) are seldom as uniform and homogeneous as the more ideal case of solutions. This leads to practical lower uncertainty limits in the 1% to 3% range. The most uniform cases of pure oxides and pure metal are often in forms that are too dense for transmission-corrected passive assay.

In the mid 1980s the New Brunswick Laboratory conducted an interlaboratory exercise that illustrated the state of the practice at that time [5]. The samples were ^{235}U contained in matrices of synthetic calcined ash, cellulose fiber, and ion-exchange resin. While the best results did fall into the 1% to 3% range previously mentioned, the majority of the respondents reported results with biases ranging from 5% to 15% indicating that the state of the practice was significantly poorer than the state of the art.

Parker [6] reported a dramatic illustration of the power and versatility of the correct application of the transmission-corrected, passive-assay method as applied to solids and liquids.

The results in Fig. 3 show that the corrected count rate/g ^{235}U is the same, to better than 1%, independent of the widely varying chemical, physical, and geometric form of the samples (Fig. 4), when proper assay methods are applied.

3. Heterogeneous Solids. The transmission-corrected, passive-assay method begins to break down for this case, scrap and waste being the prime example. The segmented gamma scan (SGS) technique [7], developed to address this problem, is commercially available and widely used, but still cannot completely cope with the general case where the matrix density varies greatly throughout the sample. For small matrix density variations, measurement accuracy can still be better than 5%. However, for more gross heterogeneities, measurement biases can be 20% to 50% or more. Particularly troublesome is the case where the high-Z SNM is contained in large particles ($>100\ \mu$) or agglomerations in which self-absorption within the particle or "lump" is not accounted for by the transmission correction.

Recent research [8,9] has improved the situation with the incorporation of "lump correction" algorithms into SGS system software. These corrections use peak ratios to help provide correction factors for self-absorption in lumps or particles within the sample and are carried out in addition to the standard, matrix-attenuation correction factor from external-source transmission measurements. This type of correction technique has been discussed extensively but never applied in the general case. Its use here improves the accuracy of the assay of heterogeneous solids but still does not remove all the bias.

Because of the problem with SNM lumps, SGS measurements of heterogeneous materials often are biased low.

IV. METHODS FOR ISOTOPIC RATIOS AND ISOTOPIC DISTRIBUTIONS

A. "Enrichment Meter"

The "enrichment meter" [9] is one of the simplest, yet most elegant and accurate applications of quantitative gamma-ray spectrometry. It can be used to measure the absolute isotopic enrichment of materials whose chemical compositions are known and are infinitely thick (for example, $>7 \lambda$) to the measurement gamma ray (typically 185 keV). It has been most often used for determining the enrichment of ^{235}U in uranium found in various physical and chemical forms in the nuclear fuel cycle although its application is certainly not limited to uranium. The same principle can also be used to measure the concentration of dilute SNM in a known matrix or the blending ratio of mixed U/Pu oxides.

Best results are obtained with germanium detectors although NaI is successfully used in many cases. Measurement systems use a rate-loss correction source and are calibrated with standards of known enrichment. The technique is so well developed and so widely used that internationally certified reference materials are available in the low enrichment range (NBS-SRM-969/EEC-NRM-171). The users manual [10] distributed with these materials contains, perhaps, the best and most complete discussion of enrichment measurements currently available.

Careful application of gamma-ray spectrometry [11] has demonstrated that uranium enrichment can be measured with an accuracy of $\pm 0.1\%$ (relative) for enrichments from 0.7% ^{235}U to above 90% ^{235}U with a single measurement system and calibration.

B. Isotopic Ratios

The measurement of the isotopic composition of plutonium with gamma-ray spectrometry is an example of using the measurement of isotopic ratios to absolutely determine isotopic distributions without recourse to calibration standards, rate-loss

corrections, or attenuation corrections. The determination of the relative detection efficiency of the measurement system from the gamma-ray spectrum of each sample is the key feature of this type of measurement. This, coupled with the fact that isotopic *ratios* are measured, makes the measurements independent of sample geometry and composition and yields absolute results without using standards. Reference [12] reviews the state of this technique as of the mid-1980s. Equation 3 presents the fundamental relation for determining ratios from measured spectral data and known nuclear-decay parameters.

$$\frac{M^i}{M^k} = \frac{C(E_j^i)}{C(E_\ell^k)} \cdot \frac{\gamma_\ell^k}{\gamma_j^i} \cdot \frac{RE(E_\ell)}{RE(E_j)} \quad (3)$$

Equation 3 shows the mass ratio M of isotope i to isotope k in terms of the net photopeak areas C of a gamma ray with energy E_j from isotope i and a gamma ray with energy E_ℓ from isotope k , the photon emission rates (γ in units of gammas/s•g isotope) of gamma rays j and ℓ and the relative detection efficiency RE at energies E_j and E_ℓ

Several sophisticated computer codes exist that apply this technique in routine production-line situations in various plutonium-handling facilities throughout the world [12,13,14]. These codes are capable of providing measurement accuracies of < 1% for ^{238}Pu , ^{239}Pu , ^{240}Pu , and ^{241}Pu . The results from these measurements are used in the interpretation of neutron coincidence counting and/or calorimetry data from the same sample to non-destructively determine the total plutonium content of samples of arbitrary size, configuration, and composition. Measurement times typically range from 30 minutes to 1 hour. Figure 5 shows a set of results demonstrating the measurement accuracy for ^{240}Pu from the FRAM code described in [14]. Here the different symbols refer to different groups of samples. The plutonium masses in these samples ranged from a few hundred mg to almost 2 kg with the chemical forms being oxide (mainly), metal, and solutions.

Measurement precision for some of the analysis methods [13] can approach or exceed that from mass spectrometry.

C. Other Applications

Two other applications of the measurement of isotopic ratios in the field of special nuclear material safeguards bear mentioning. The first is the measurement of isotopic ratios of fission products in spent fuel to determine the burnup of the fuel. This application can be applied by safeguards inspection authorities. The second involves the measurement of the $^{235}\text{U}/^{238}\text{U}$ ratio in arbitrary samples found in the nuclear fuel cycle [15]. The latter application is difficult using the same relative efficiency techniques used for plutonium because of the wide energy separation between the principle gamma rays from ^{235}U (~200 keV) and those from the $^{234\text{mPa}}$ daughter of ^{238}U (~700-1000 keV). Nevertheless, in at least one instance, the same code used in plutonium measurements [14] can also be used to measure uranium isotopic ratios.

IV. METHODS FOR ELEMENTAL CONCENTRATION

A. Absorption-Edge Densitometry

Densitometry uses the measured transmission through the sample of photons from an external source at energies above and below the K (or L) absorption edges of the SNM to determine the elemental concentration in the sample as denoted in Eq. 4.

$$\rho = \ln(T_{\text{above}}/T_{\text{below}})/(\mu_{\text{edge}} \cdot D), \quad (4)$$

where ρ = elemental density, T_{above} = sample transmission above absorption edge,
 T_{below} = sample transmission below absorption edge, μ_{edge} = difference in mass

absorption coefficients at the energies of T_{above} and T_{below} , and D = sample thickness. It is usually applied to solution samples and has been used for plutonium with isotopic transmission sources of ^{75}Se (121.1 keV) and ^{57}Co (122.0 keV) straddling the 121.8 keV K-absorption edge of plutonium. Continuous spectrum photons from x-ray tubes have also been used at both the K and L edges for uranium and plutonium. Numerous references to early work in the safeguards application of this gamma-ray spectrometry technique may be found in [16]. Measurement accuracies and precisions in the range of 0.5% or better can be achieved with these methods.

Calibration is usually accomplished with standards although fundamental data can be used for μ_{edge} and D to carry out measurements without standards.

A very interesting application (Fig. 6) of this technology has been developed at Kernforschungszentrum Karlsruhe in the form of a hybrid K-edge densitometer/K x-ray fluorescence (XRF) instrument [17,18]. Its primary purpose is to measure both the uranium and plutonium concentrations in solutions from the reprocessing of spent fuel, the most important measurement point being the highly radioactive dissolver solution ($\sim 1 \text{ Ci/cm}^3$) in the input accountability tank. In this instrument densitometry is used to determine the uranium concentration and XRF is used to determine the Pu/U ratio (typically 0.01). An x-ray generator is used for both measurements; separate sample cells allow both the densitometry and XRF measurement to be performed simultaneously. Results are comparable to or better than the traditional isotope dilution mass spectrometry method for obtaining plutonium concentrations in dissolver solutions.

B. X-ray Fluorescence

The x-ray fluorescence technique is well known and widely used in many applications outside the nuclear materials safeguards area. Most applications to date, both within and outside the safeguards measurement area, are plagued with the problem of matrix effects—absorption of the exciting and fluoresced radiation by the sample as well as

secondary emissions excited by the fluoresced radiation from the sample. Much work has been done on so-called fundamental parameters analysis procedures. However, until the work described in [19], it seems as if no one has attempted to apply the principles of transmission-corrected passive assay to this problem. It is, of course, quite difficult to do for the general case where many elements are being measured simultaneously. However, for the case of special nuclear materials where only a few elements are considered, the problem becomes entirely tractable.

A successful application of transmission-corrected XRF has been reported by Ruhter and Camp [20]. This situation is more complex than the transmission corrections discussed above because corrections must be made for absorption of both the exciting radiation and the fluoresced x rays. They use an external source of ^{57}Co to measure the transmission of the sample at the energy of the exciting photons, also from ^{57}Co . A source of ^{153}Gd (97.4 and 103.2 keV) is used to measure the transmission of the sample at the energy of the primary fluoresced x rays from uranium (98.4 keV, U $K\alpha_1$) and plutonium (103.7 keV, Pu $K\alpha_1$). The attenuation correction factors are calculated using the same formalism as described in [1]. This yields a linear calibration curve, independent of solution concentration, matrix density, and composition. No longer are "representative" standards needed for calibration, and as above, only a single standard is required for calibration.

Measurement accuracies of about 0.5% have been demonstrated over a range of uranium and plutonium concentrations from 1 g/l to 250 g/l in acid concentrations ranging from 1 M to 9 M.

It may be of interest to note that x-ray fluorescence was chosen for this application over the competing densitometry technique because XRF generally operates over a wider SNM concentration range than does densitometry.

VI. SUMMARY

The applications of gamma-ray spectrometry used in the quantitative assay of SNM can be considered as methods that measure (1) isotopic masses or concentrations typified by transmission-corrected passive assay; (2) isotopic fractions or distributions, with examples being the "enrichment meter" and plutonium isotopic composition measurements; and (3) elemental concentrations with examples being absorption-edge densitometry and x-ray fluorescence.

Correct and careful practice of these techniques can yield measurement accuracies in the range of 0.1% to 1.0% in favorable situations. Typical measurement precisions are similar; measurement times usually range from 15 minutes to 1 hour.

These techniques are widely used for measuring special nuclear materials in ways that are not widely applied in other areas of gamma-ray spectrometry.

REFERENCES

1. J. L. Parker, "The Use of Calibration Standards and the Correction for Sample Self-Attenuation in Gamma-Ray Nondestructive Assay," Los Alamos National Laboratory report LA-10045, Rev. (November 1986).
2. J. L. Parker, T. E. Sampson, L. R. Cowder, E. A. Kern, D. L. Garcia, and N. Ensslin, "The Development of a State-of-the-Art Assay System for Uranium-235 in Solutions," Los Alamos National Laboratory report LA-10793-MS (December 1986).
3. T. E. Sampson, J. L. Parker, L. R. Cowder, E. A. Kern, D. L. Garcia, and N. Ensslin, "A State-of-the-Art Passive Gamma-Ray Assay System for ^{235}U in Solution," *Proceedings of the 9th ESARDA Symposium on Safeguards and Nuclear Material Management*, London, U.K., May 12-14, 1987, EUR 11041 EN/ESARDA 21, pp. 219-224.
4. T. E. Sampson and A. Goldman, "Analysis of NDA Instrument Calibration Data," Los Alamos National Laboratory report LA-11316-MS (August 1988).
5. Nancy M. Trahey, Marianne M. Smith, Anna M. Voeks, and Jere T. Bracey, "Interlaboratory Comparison Program for Nondestructive Assay of Prototype Uranium Reference Materials," U. S. Department of Energy, New Brunswick Laboratory report NBL-306 (December 1986).
6. Jack L. Parker, "Practical Standards for Passive Gamma-Ray Assay," *Transactions of the American Nuclear Society*, 39, 319 (1981).
7. E. R. Martin, D. F. Jones, and J. L. Parker, "Gamma-Ray Measurements with the Segmented Gamma Scan," Los Alamos Scientific Laboratory report LA-7059-M (December 1977).
8. J. K. Sprinkle, Jr., and S. -T. Hsue, "Recent Advances in Segmented Gamma Scanner Analysis," *Proceedings, Third International Conference on Facility Operations - Safeguards Interface*, San Diego, California, November 29 - December 4, 1987, American Nuclear Society Order No. 700132, pp. 188-193.
9. T. D. Reilly, R. B. Walton, and J. L. Parker, "The 'Enrichment Meter'--A Simple Method for Measuring Isotopic Enrichment," in Los Alamos Scientific Laboratory report LA-4605-MS (January 1971), pp. 19-21.
10. P. Matussek, "Accurate Determination of the ^{235}U Isotope Abundance by Gamma Spectrometry -- A User's Manual for the Certified Reference Material EC-NRM-171/NBS-SRM-969," Kernforschungszentrum Karlsruhe report KfK 3752 (May 1985).
11. J. L. Parker and M. Brooks, "Accurate, Wide-Range Uranium Enrichment Measurements by Gamma-Ray Spectroscopy. I. Characterization of Enrichment Standards, II. Demonstration of Enrichment Measurement Capability," Los Alamos National Laboratory report LA-11277-MS (September 1988).

12. T. E. Sampson, "Plutonium Isotopic Composition by Gamma-Ray Spectroscopy: A Review," Los Alamos National Laboratory report LA-10750-MS (September 1986).
13. Ray Gunnink, "A New One-Detector Analysis Method for Rapid High-Precision Plutonium Isotopic Measurements," *Proceedings of the 9th ESARDA Symposium on Safeguards and Nuclear Material Management*, London, U.K., May 12-14, 1987, EUR 11041 EN/ESARDA 21, pp. 167-171.
14. Thomas E. Sampson, George W. Nelson, and Thomas A. Kelley, "FRAM: A Versatile Code for Analyzing the Isotopic Composition of Plutonium from Gamma-Ray Pulse Height Spectra," Los Alamos National Laboratory report LA-11720-MS (December 1989).
15. J. R. S. Harry, J. K. Aaldijk, and J. P. Braak, "Gamma-Spectrometric Determination of Isotopic Composition without Use of Standards, IAEA-SM-201/66, in: *Safeguarding Nuclear Materials*, Vienna 1976, Vol. II, p. 235.
16. P. A. Russo, S. -T. Hsue, D. G. Langner, and J. K. Sprinkle, Jr., "Nuclear Safeguards Applications of Energy-Dispersive Absorption Edge Densitometry," *Nuclear Materials Management* 9, 730 (1980).
17. H. Ottmar, H. Eberle, and L. Koch, "Demonstration of NDA Technology for Reprocessing Input Analytical Measurements," *Nuclear Materials Management* XV, 632 (1986).
18. S. -T. Hsue and H. Eberle, "Application of the Hybrid X-Ray Instrument for Measurement of Thorium-Plutonium Mixed Solutions," Los Alamos National Laboratory report LA-11002-MS (July 1987).
19. T. R. Canada, D. C. Camp, and W. D. Ruhter, "Single-Energy Transmission-Corrected Energy-Dispersive XRF for SNM-Bearing Solutions," *Proceedings of 23rd Annual Meeting of the Institute of Nuclear Materials Management, Nuclear Materials Management* XI, 246 (1982).
20. Wayne D. Ruhter and David C. Camp, "Transmission-Corrected X-ray Fluorescence Analysis of Uranium and Plutonium Solutions Using a Dual Transmission Source," *Proceedings, Third International Conference on Facility Operations - Safeguards Interface*, San Diego, California, November 29 - December 4, 1987, American Nuclear Society Order No. 700132, pp. 300-305.

FIGURE CAPTIONS

Fig. 1. A measurement system for ^{235}U solution samples using the transmission-corrected passive assay technique [2,3].

Fig. 2. Comparison of calibration data from two sets of calibration standards for the system described in [2,3].

Fig. 3. Correct application of transmission-corrected passive assay produces results independent of the sample's physical and chemical composition and geometry.

Fig. 4. The samples used in the measurements of Fig. 3.

Fig. 5. Measurement accuracy for ^{240}Pu for a wide range of sample types and compositions [14].

Fig. 6. A cross-sectional plan of the hybrid K-edge densitometer [17].

AT-LINE SOLUTION ASSAY SYSTEM

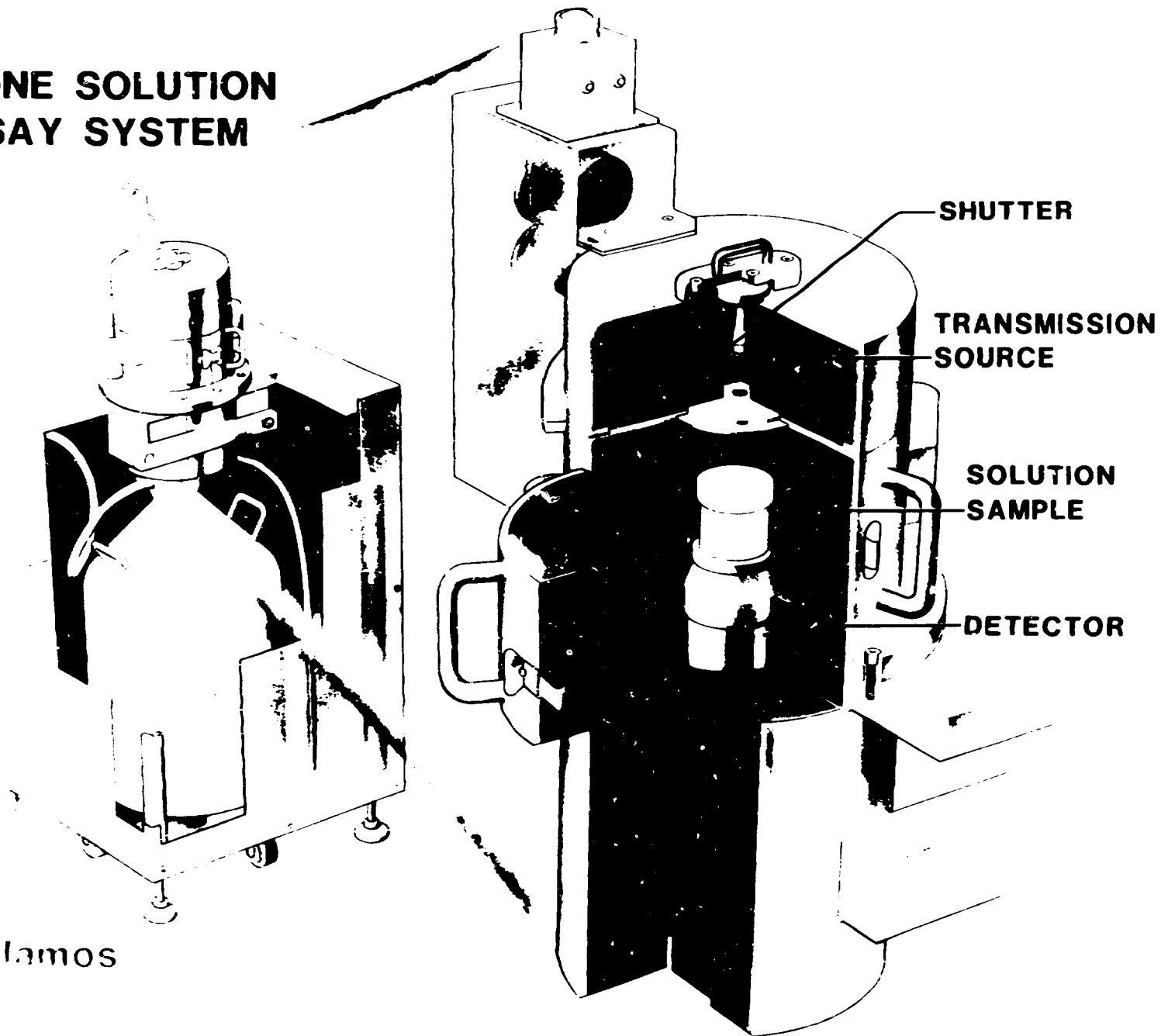

Los Alamos

Fig. 1 (Sampson)

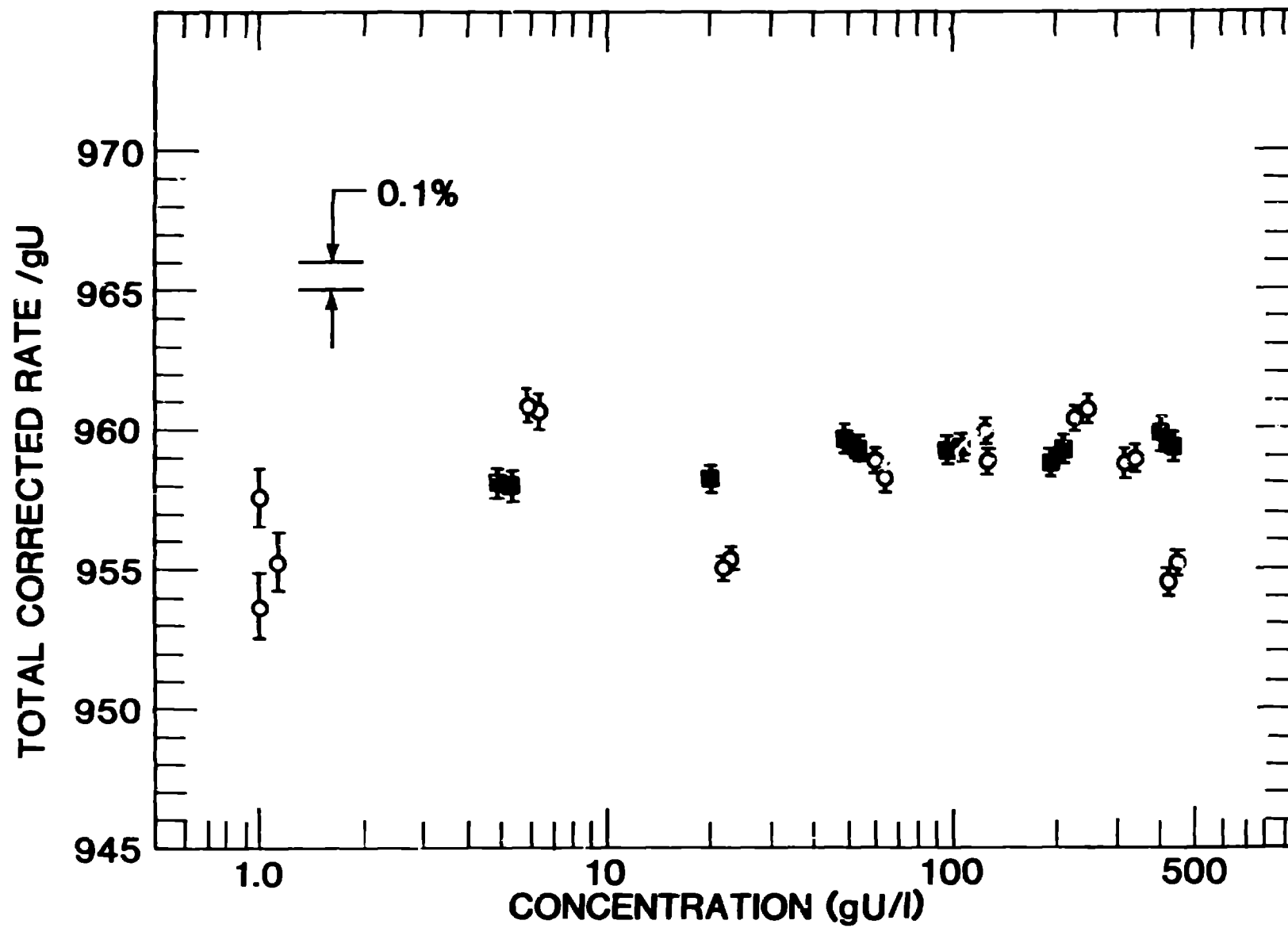

Fig. 2 (Sampson)

Transmission-Corrected Passive Assay

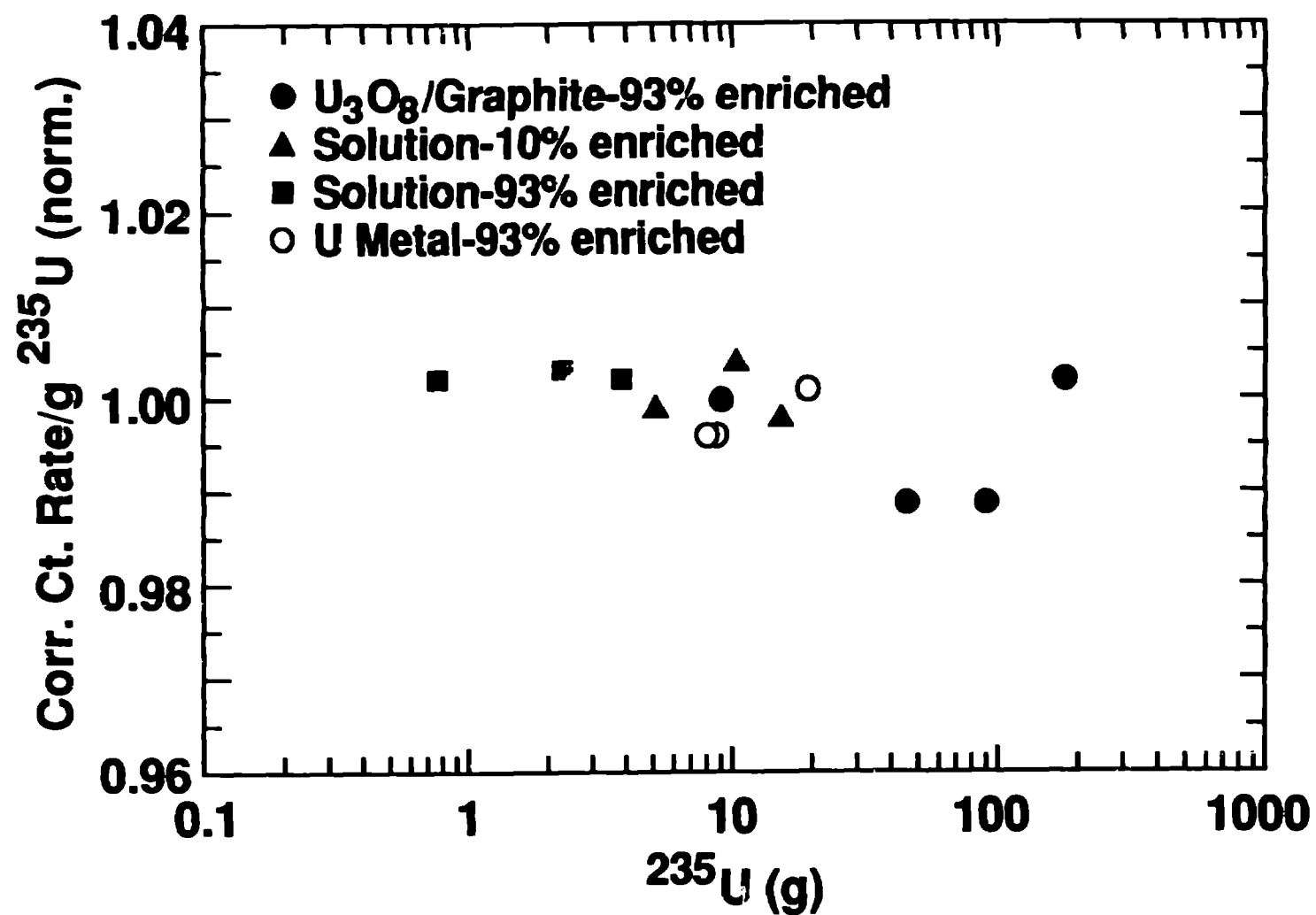

Fig. 3 (Sampson)

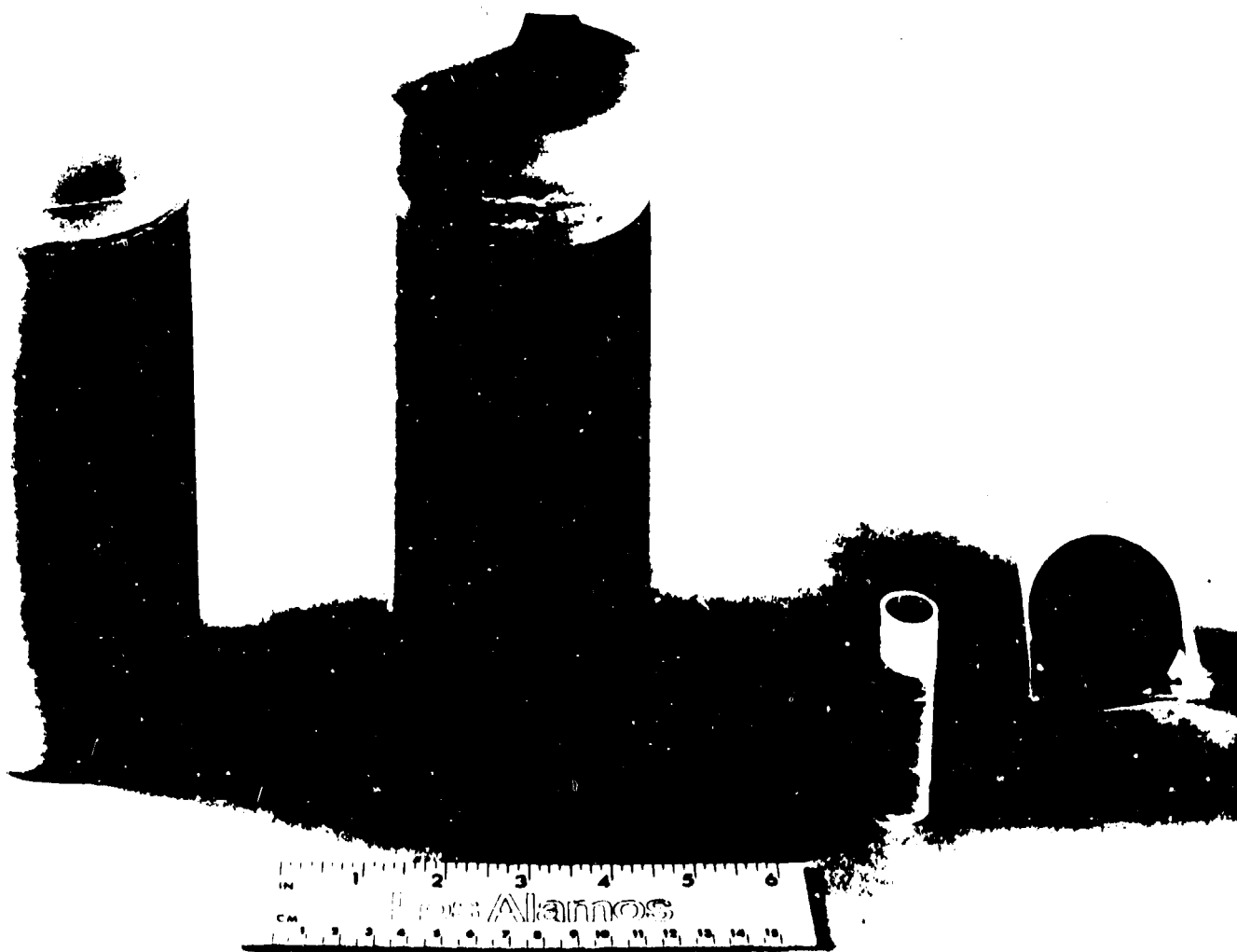

Fig. 4 (Sampson)

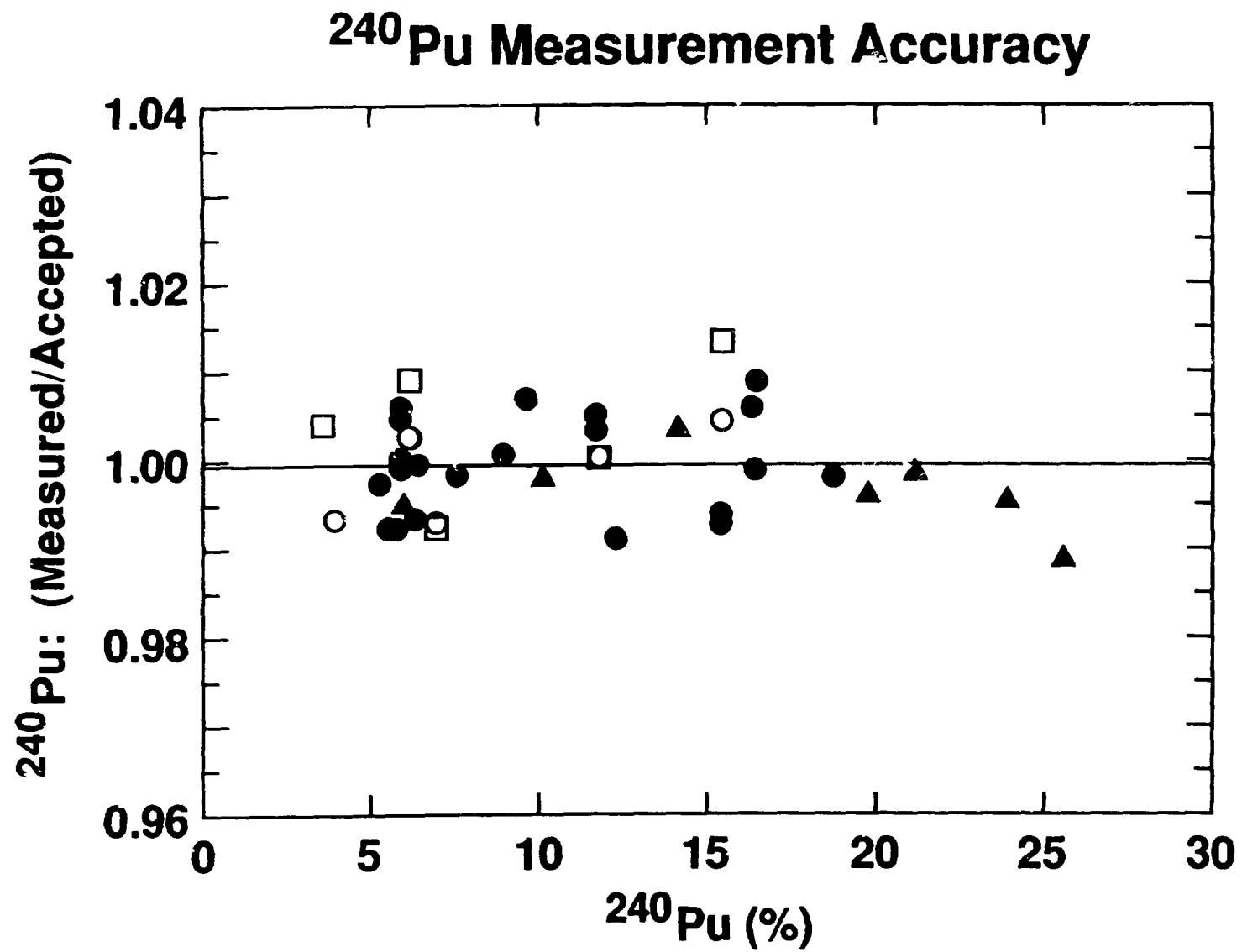
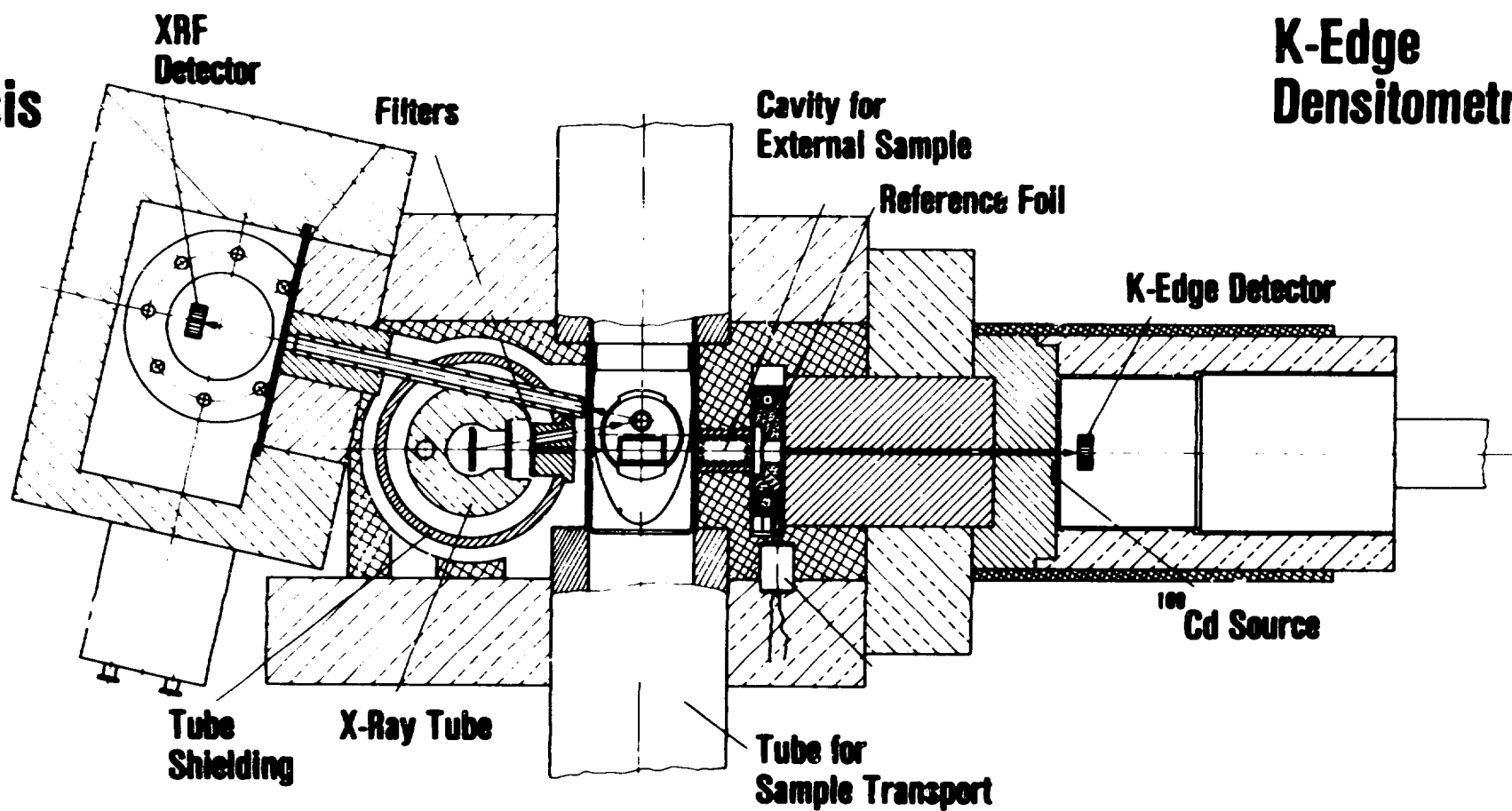

Fig. 5 (Sampson)

K-XRF Analysis



K-Edge Densitometry

Fig. 6 (Sampson)